



A CHLORIDE POWER PROTECTION COMPANY

# **ONEAC Total Protection Installation Handbook**

## **For Telecom Systems**

## INTRODUCTION

*Telecom systems have changed dramatically over the last several years, evolving into “Telecomputers.” Compared to past technologies, today’s telecom systems are more sensitive to transient influence and more expensive to install, repair and maintain. Thus, the quality of the customer’s power and grounding environment (installing the system according to the manufacturer’s recommendations combined with “protection” of the equipment) are more critical to the system’s performance and reliability than ever before.*

The ONEAC Total Protection Solution was designed to meet the demanding protection needs of today’s microprocessor-based telecommunications systems. It provides for a clean, quiet and stable electrical environment for all power and communications equipment. Total protection, however, requires the assurance that all power and communications paths are connected to the appropriate ONEAC protection devices.

**WARNING:***Any unprotected equipment, cable or peripheral devices connected to the telecom system, provide a path for damaging electrical noise and can reduce the effectiveness of ONEAC protection.*

We designed this handbook to help installers ensure the electrical environment and associated cabling are properly installed, grounded and protected by the required ONEAC devices. The following installation guidelines have proven to:

- Dramatically reduce service calls.
- Improve system performance, reliability.
- Increase customer satisfaction.
- Reduce maintenance material, labor costs.

## TECHNICAL SUPPORT

ONEAC offers 24-hour technical support. To contact ONEAC Technical Services:

- North America: (800) 327-8801 (opt. 3) or (847) 816-6000 (opt. 3)
- Europe: +44 (0) 1235 534721
- email: [ts@oneac.com](mailto:ts@oneac.com).

All calls received before 7 a.m. or after 7p.m. Central Standard Time are forwarded to a cell phone. An ONEAC Technical Support Representative will return your call within one half hour between 5 p.m. and 10 p.m. Central Standard Time. Except for emergencies, calls received between 10 p.m. and 7 a.m. will be returned during normal business hours.

Please check with ONEAC Technical Services before attempting to repair or return any ONEAC product. If an ONEAC unit needs repair or replacement, ONEAC Technical Services issues a Return Material Authorization (RMA) number along with instructions on how to return the unit.



## TABLE OF CONTENTS

Part 1: ONEAC Total Protection Solution Components.....	5
Part 2: How to Size ONEAC Power Conditioner/UPS Devices (PPD).....	7
Part 3: Testing the AC Outlet.....	9
The Outlet Configuration.....	9
Is The Outlet Acceptable? .....	9
Part 4: The Four Basic Rules of ONEAC Total Protection .....	11
Part 5: Installing ONEAC Total Protection Solutions Sections 1 - 4 .....	13
Section 1: Installing the ONEAC Power Protection Device (PPD) .....	13
Section 2: Communications Line Protection Device (CLPD).....	14
OnLine 6-Series .....	14
Product Description .....	14
General Requirements .....	15
Tools and Materials for Installation .....	15
Installation Using 66 Block .....	15
OnLine 5S-Series .....	17
Product Description .....	17
General Requirements .....	17
Tools and Materials for Installation .....	18
Installation .....	18
OnLine 1-Series .....	19
Product Description .....	19
General Requirements .....	20
Tools and Materials for Installation .....	20
Installation .....	20
OnLine RJ-Series .....	22
Product Description .....	22
Product Specifications .....	22
General Requirements .....	22
Tools and Materials for Installation .....	23
Installation .....	23
Convergent Series .....	25
Product Description .....	25
General Requirements .....	25
Tools and Materials for Installation .....	25
Installation .....	25
Single Point Ground Adapter Kit for ONEAC Power Protection Devices .....	27
Product Description .....	27
Tools and Materials for Installation .....	27
Installation .....	27
Section 3: Total Protection Solution Installed .....	29
Section 4: OPX Cable Application .....	29
Part 6: National Electrical Code Section.....	31



## Part 1: ONEAC Total Protection Solution Components

### 1. ONEAC Power Protection Devices (PPDs), e.g. Power Conditioners/UPSs

ONEAC UPS products include power conditioning in their design. Therefore, the use of a separate power conditioner is not required. See How to Size a Power Conditioner or UPS for sizing information and product selection.

### 2. ONEAC Communications Line Protection Device (CLPD)

Protection is required on each wire of the communications cabling (CO, OPX, Data, T1, etc). See product information to determine which device to use for paired, unpaired, multi-paired and multiple wire communications systems.

### 3. ONEAC Protector Ground Bar (350-032)

One required for each 25 pair block when using OnLine® 6-Series protectors.

### 4. Single Point Ground Adapter Kit (350-055)

Backboard mounted ground bar for “Single Point Grounding” of ONEAC PPDs, Telephone Line/Communications Circuit Protection, System Cabinet (if required) and associated peripheral equipment.

### 5. Stranded or Solid Copper Insulated 6 AWG Ground Wire

Required Tools & Test Equipment: Standard telecom installation tools and a digital multimeter are required.

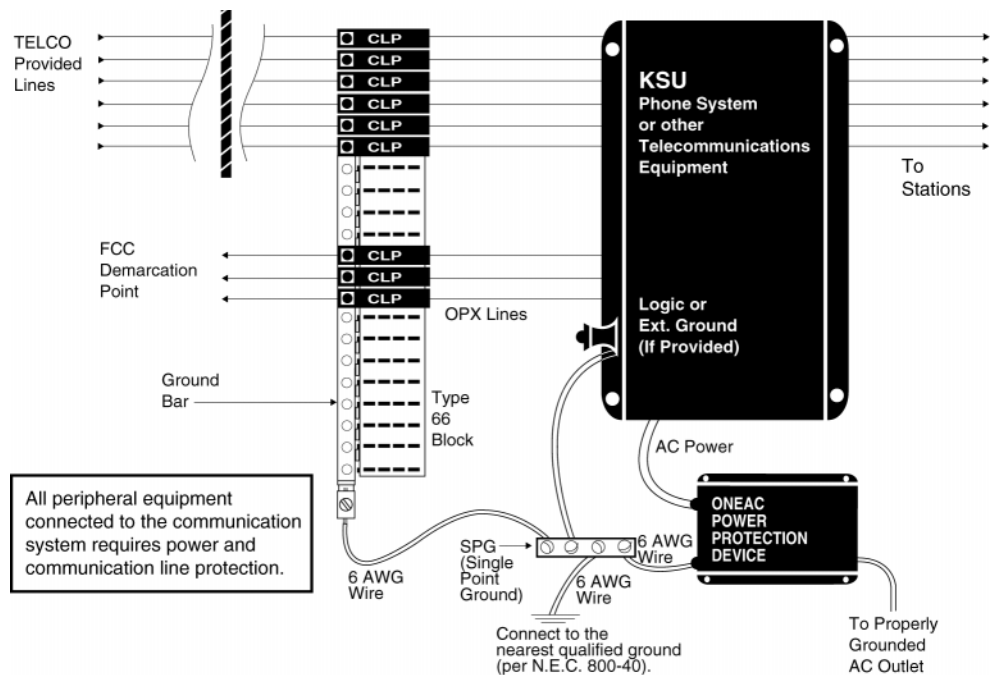

Fig 1 Typical Telecom Setup

*ONEAC Total Protection Solution Components*

## Part 2: How to Size ONEAC Power Conditioner/UPS Devices (PPD)

Follow these guidelines when specifying ONEAC Power Conditioners or UPS Battery Backup Systems:

### 1. Determine the Voltage Rating

The sizing of ONEAC PPDs is based on operating voltage (120 V or 240 V), current draw (measured in Amps) and power consumption (rated in Watts or VA). Total protection requires assurance that the PPDs are sized to handle the largest system configuration of the equipment involved. Be sure to include any peripherals, modems, maintenance terminals, etc., requiring protection by a single conditioner or UPS.

### 2. Determine the Total Power (VA)

The preferred method is to measure the true RMS current draw of the equipment and all peripherals. Multiply the measured current times the operating voltage to derive Volt-Amps (VA).

If it is not possible to measure the true load current, an estimate of the load power can be derived from the equipment name plates normally found where the input power cord connects to the equipment.

### 3. Determine the Plug/Receptacle Type

ONEAC power conditioners and UPSs are available with a variety of different plug and receptacle configurations to match most any system.

There are two basic types of plugs and receptacles: straight blade and twist-lock. Twist-lock plug and receptacles have the prefix L before the number, for example, L5-15P (plug) or L5-15R (receptacle).

The most common voltage ranges are “5” (110-120 V) and “6” (240-250 V). For ease of reference and sizing, your ONEAC specification sheets list various plug types, load carrying capacities, sizes, weights, etc.

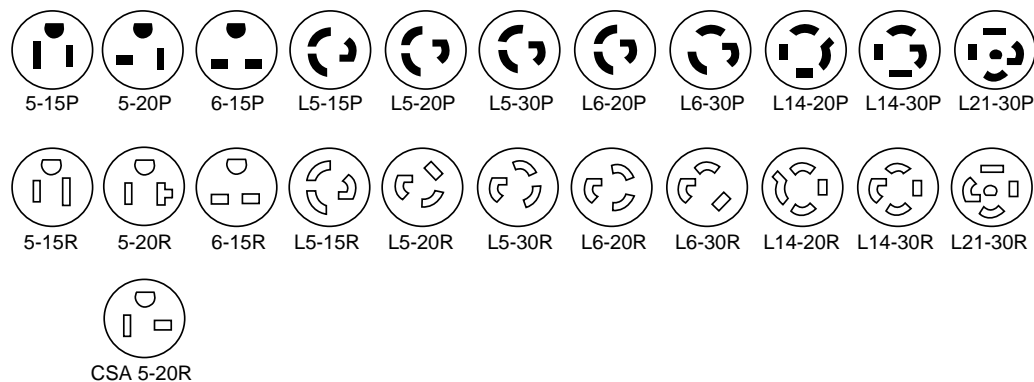

Fig 2 Common Plug and Receptacle Types.

To help you understand plug and receptacle abbreviations, we have included a short summary of what they mean. The example, shown below, uses a 5-15P as it would typically be listed in a manufacturer’s specifications:

- The operating voltage precedes the hyphen. The 5 means the plug is recommended for circuits rated at 110-120 V.
- The current rating follows the hyphen. In this case, it is 15A.
- The “P” means plug. An “R” would mean receptacle.



## *How to Size ONEAC Power Conditioner/UPS Devices (PPD)*

### **4. Making your Selection**

Voltage, wattage, current and plug configurations should be paired to the ONEAC power conditioner or UPS that best matches the system's parameters or back up time desired. Refer to ONEAC's product catalog or specification sheet to size the appropriate product for the application.

If you have questions regarding your selection or a specific application, call ONEAC Technical Service (1-800-327-8801, opt. 3) or contact your ONEAC Account Manager for assistance.

## Part 3: Testing the AC Outlet

**NOTE:** Before installing and powering telecom equipment, make certain that the outlet being used for the installation is wired correctly and provides acceptable voltage and resistance readings. Failure to complete this step can cause system damage, poor protection or degraded system performance. Tests should only be performed by a qualified technician using a digital multimeter.

### The Outlet Configuration

There are three slots in a standard 120 VAC outlet:

- **Hot:** The hot conductor delivers energy to the load (telephone system) through the smaller vertical slot, see Fig 3. It connects to a fuse or breaker at the service panel.
- **Neutral:** The neutral conductor is grounded and completes the circuit from the load (telecom system) to the service panel. It is typically referred to as the system ground and is the longer vertical slot.
- **Ground:** The ground conductor is the hole below the two vertical slots (hot and neutral) and provides a path for fault current between the load (telecom system) and earth. It is also known as the equipment ground.

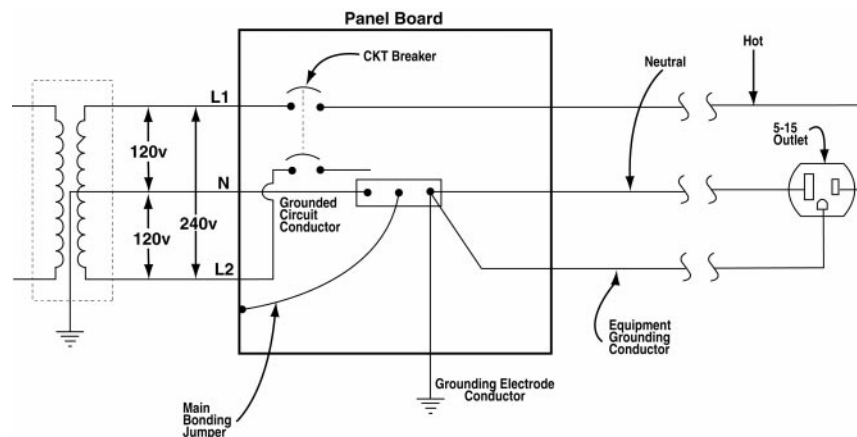

Fig 3 Outlet Configuration

### Is The Outlet Acceptable?

The following steps will aid the technician in determining the AC outlet's acceptability. This test does not determine the quality or condition of the power at the outlet relative to transient noise, sags, surges, etc.

**WARNING:** Do not take these readings during lightning or thunderstorm activity.

1. Measure the AC voltage between the HOT and NEUTRAL using the AC voltage scale. This reading should be approximately 115 VAC  $\pm$  10 VAC.

### *Testing the AC Outlet*

**2.** Measure the AC voltage between the HOT and the GROUND using the AC voltage scale. This reading should be approximately 115 VAC  $\pm$  10 VAC. The readings in Step 1 and Step 2 should be very close to the same.

**3.** Measure the AC voltage between the NEUTRAL and the GROUND using the AC voltage scale. This reading should be less than 2VAC.

**4.** Measure the resistance between the NEUTRAL and the GROUND using the resistance scale. ONEAC recommends a resistance reading of 0.5 OHM or less.

*NOTE: If the readings are acceptable as outlined in Steps 1-4 above, the Telecom System and the ONEAC Total Protection can be installed.*

If these readings are not acceptable, a qualified electrician should be contacted to correct the condition. Again, failure to follow these steps may result in system damage, poor protection or degraded system performance.

## **Part 4: The Four Basic Rules of ONEAC Total Protection**

**RULE 1:** All AC powered components in the telecom system must be powered/protected through an ONEAC PPD.

**RULE 2:** All CO, OPX and other lines entering the system from outside the building must be protected by an ONEAC Communications Line Protection Device (CLPD).

**RULE 3:** The PPD's ground bar is the system's single point ground. All system grounds must be brought to this point before grounding to the building grounding electrode.

**RULE 4:** All OPX cables entering the system must be installed and protected per National Electrical Code (N.E.C.) requirements. Refer to the N.E.C. section of this handbook for related code information (see page 32).

**NOTE:** *This handbook puts these four rules into practice. Our purpose is to give technicians an overview of the instructions included with every ONEAC Power Protection Device. The complete booklet should be carefully studied by technicians who are unfamiliar with the ONEAC TOTAL PROTECTION SOLUTION.*

*The Four Basic Rules of ONEAC Total Protection*

## **Part 5: Installing ONEAC Total Protection Solutions Sections 1 - 4**

### **Section 1: Installing the ONEAC Power Protection Device (PPD)**

**1.** Determine the current draw of the telecom system requiring protection. Make certain the total power requirements of the equipment do not exceed the rating listed on the PPD. Test the outlet as explained earlier in Part 3: on page 9.

**2.** Select an easily accessible location for mounting the ONEAC power conditioner or UPS. Be sure the PPD's cord reaches the customer's AC outlet and that all cords (KSU, PBX, peripherals, etc.) plugged into the PPD are long enough to reach it.

**IMPORTANT:** *There should be adequate clearance for ventilation (see Users Manual for recommendations). Do not stack equipment or PPD devices. Assess requirements for mounting/routing station cables, power cords, single point ground bar (SPG), ground wire runs, etc.*

**3.** Check that the power switch is off on the KSU, PBX or other peripheral equipment. Plug all AC line cords from the telecom system into the output receptacle(s) of the ONEAC PPD.

**4.** Plug the AC line cord of the PPD into the customer-provided receptacle.

**5.** Mount the single point ground bar (SPG) to the backboard. Once again, consider future ground wire runs.

**6.** Terminate the telecom system ground, ONEAC PPD ground and any peripheral equipment ground to the ONEAC SPG. Avoid sharp bends when routing ground wires. Allow as much separation as is practical between station wires, foreign ground wires, hardware, etc. Preferably, 2" or more are recommended to prevent transient coupling between conductors. Do not bundle ground wires, station wires and/or power cords together.

7. Run a secondary earth ground of 6 AWG from the SPG to the building grounding electrode. Refer to the N.E.C. section of this booklet for related code articles, see Fig 4.

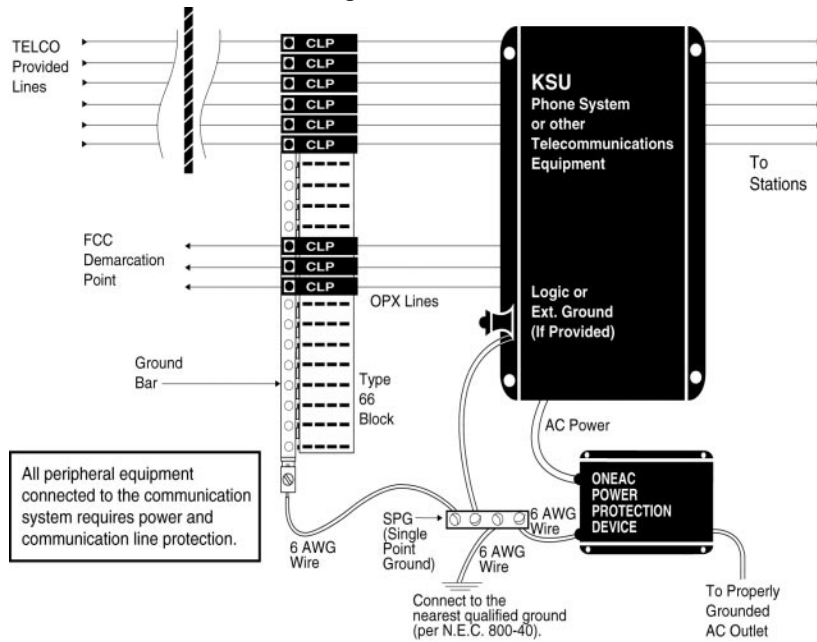
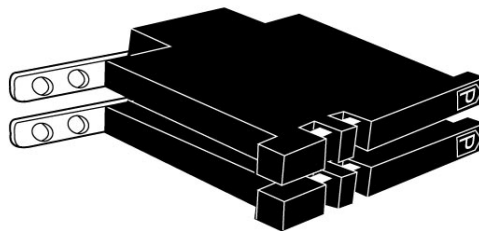

Fig 4 Typical Telecom Setup

**NOTE:** The regulated telecom cable/protection ground should remain as a separate ground run to the building grounding electrode. Do not attach the 6 AWG from the ONEAC SPG to the regulated telecom ground.

## Section 2: Communications Line Protection Device (CLPD)

### OnLine 6-Series Telephone Line Protectors



#### Product Description

The OnLine 6-Series is a UL listed primary and secondary protector designed to work with a 66 M1-50 type cross-connect block that can be installed in accordance with Article 800 of the National Electrical Code, ANSI/NFPA 70. OnLine 6-Series protectors modules must be installed in a UL listed base in order to provide UL compliant installations.

The OnLine 6-Series protectors use patented “switched filter technology” that provides transient let-through voltages below the DC breakdown voltage of the protector, in combination with low loss and fast reaction time.

## General Requirements

- The OnLine 6-Series protector modules provide primary and secondary protection. No installation is safe from phone line transient damage, unless OnLine 6-Series protector modules are installed on all phone lines.
- When employed for primary protection, the OnLine 6-Series modules must be enclosed in a listed Type 1 NEMA enclosure with fusing conductors no larger than 20 AWG bridle wire or 22 AWG solid copper wire with thermoplastic insulation.
- Install OnLine 6-Series modules on a standard 66 M1-50 block in place of bridging clips. Do not install protector modules on the telco demarcation point block.
- One OnLine 6-Series module is required for each line (twisted pair).
- One ONEAC Ground Bar (Part No. 350-032) is required for each 66 block on which protector modules are to be installed.
- Prior to installing secondary protector modules, disconnect the telephone line at the network interface.
- Avoid bundling CO or OPX cable with inside wiring and ground conductors.
- All protector modules must be properly grounded for effective operation. In order to achieve Total Protection, ONEAC power conditioners or UPSs are recommended for protecting the phone system's AC power input and provide the best grounding.
- Installation and grounding of primary/secondary protector modules must be in accordance with Local Codes and Article 800 of the National Electrical Code, ANSI/NFPA 70.
- Intended for indoor use only.
- Never install telephone wiring during a lightning storm.

**CAUTION:** *The OnLine 6-Series protector modules contain resettable over-current protection (sneak current). As soon as a failure has cleared, the protector modules will return to their normal state.*

## Tools and Materials for Installation

- Type 66 Block
- Straight Blade Screwdriver
- 6 gauge (AWG) Wire
- ONEAC Ground Bar Assembly (Part No. 350-032)

## Installation Using 66 Block

1. Locate or install one or more type 66 blocks M1-50 with the pairs requiring protection.

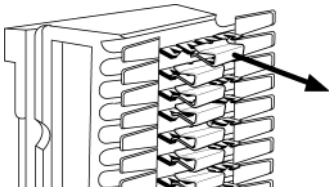

2. Start at the top of the block, and locate the first pair:

a) Remove the two bridging clips, and place them aside.

b) Align the OnLine 6-Series protector module over the pins where the bridging clips were installed. Verify that the protected side "P" is facing towards the equipment side being protected and that the ground tab is on the opposite side.

c) Fully insert the protector module into the block until the unit makes contact with the fanning strip on both sides.

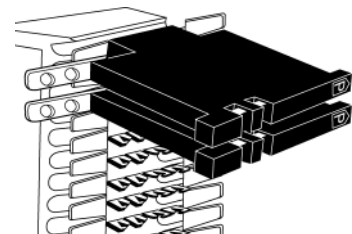

Repeat steps 2a. through 2c. for each pair on the block and for each of the blocks.

3. Check the ONEAC ground bar to ensure the ground clip is attached. The set screw should face towards you with the tab bending away from you.



Installing ONEAC Total Protection Solutions Sections 1 - 4

4. Align the ONEAC ground bar behind the screws on the ground tabs of each protector. Fasten the bar by tightening the grounding screw on each protector module.

**CAUTION:** Do not exceed 21 in.- lbs. when tightening the grounding screw.

5. Attach a 6 AWG ground wire to the ground bar clip, and tighten the set screw.

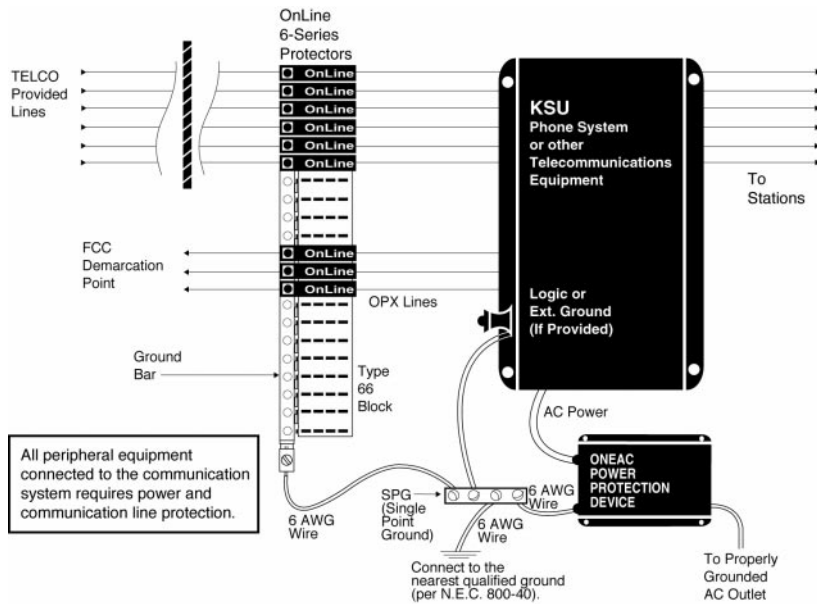
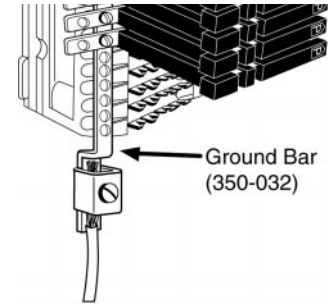

Fig 5 OnLine 6-Series Circuit Drawing

6. When wiring, take the shortest and most direct path to ground. Avoid sharp turns and kinks in ground wires. With multiple installations, several ground bars can easily be daisy-chained together.

There are two options for grounding OnLine 6-Series protector modules:

a) If your system is protected by an ONEAC Power Protection Device: Run a 6 AWG ground wire from the ground bar assembly (Part No. 350-032) to the Single Point Ground. Next, run a 6 AWG ground wire from the Environmental Reference Ground® screw of the ONEAC Power Protection Device to the Single Point Ground. Then, complete the installation by running a 6 AWG ground wire from the Single Point Ground to the nearest qualified ground.

– OR –

b) If your system is not protected by an ONEAC Power Protection Device: Run a 6 AWG ground wire from the ground bar assembly (Part No. 350-032) to the nearest qualified ground.

7. Inspect all protector modules and ground wires to ensure they are tightly fastened to the ground bar.

8. Check phone line operation. If any test fails, recheck to ensure the OnLine protector modules are:

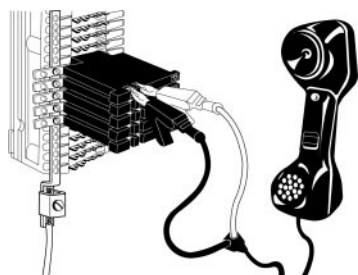

a) Properly seated in the block.

b) Not bridging between two adjacent pairs.

**TIP AND RING TESTING:** The OnLine 6-Series enables Tip and Ring testing without removing the modules from the block. ONEAC's design provides easy access on the input side that will enable the technician to clip their Telco Test Set directly to the OnLine 6-Series module. Therefore, there is no need to interrupt phone service while performing Tip and Ring tests.

## OnLine 5S-Series



### Product Description

The OnLine 5S-Series is a UL listed primary 5-pin protector that can be installed in accordance with Article 800 of the National Electrical Code, ANSI/NFPA 70. OnLine 5S-Series protector modules must be installed in a UL listed base in order to provide UL compliant installations.

The 5S-Series incorporates an innovative, balanced Fail-Safe Design to ensure that both the Tip and Ring will simultaneously fail to ground when either side is exposed to a fail-safe condition. Other protectors may have only one side fail-safe, while the other side retains continuity, placing the equipment behind it at risk.

The OnLine 5S-Series protectors use patented "switched filter technology" that provides transient let-through voltages below the DC breakdown voltage of the protector, in combination with low loss and fast reaction time.

### General Requirements

- The OnLine 5S-Series protector modules provide primary protection. No installation is safe from phone line transient damage, unless OnLine 5S-Series protector modules are installed on all phone lines.
- One OnLine 5S-Series module is required for each line (twisted pair).
- Avoid bundling CO or OPX cable with inside wiring and ground conductors.
- All protector modules must be properly grounded for effective operation. In order to achieve Total Protection, ONEAC power conditioners or UPSs are recommended for protecting the phone system's AC power input, therefore providing the best grounding.
- Installation and grounding of primary protector modules must be in accordance with Local and National Electrical Codes.
- Intended for indoor use only.
- Never install telephone wiring during a lightning storm.

## Installing ONEAC Total Protection Solutions Sections 1 - 4

**CAUTION:** The OnLine 5S-Series protector modules may contain resettable over-current (sneak current) protection. As soon as the failure clears, the protector modules will return to their normal state.

### Tools and Materials for Installation

#### 5-Pin Protector Base

#### Installation

1. Locate or install one or more 5-pin protector bases.
2. When installing OnLine 5S-Series protector modules, place the module in the detent position. In the detent position, subscriber or CO equipment will be disconnected from the outside plant cable pair. When the module is fully inserted, subscriber or CO equipment is connected to the outside plant cable pair.

**NOTE:** The ground pin provides continuity to the connector base ground terminal. The base must be grounded to a locally approved grounding field for the 5S-Series to function properly.

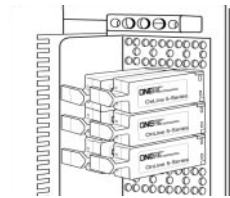
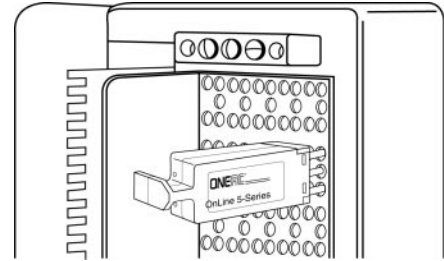

3. OnLine 5S-Series protectors are installed in the protector module mounting field. The modules are keyed so the units can only be installed in one way.

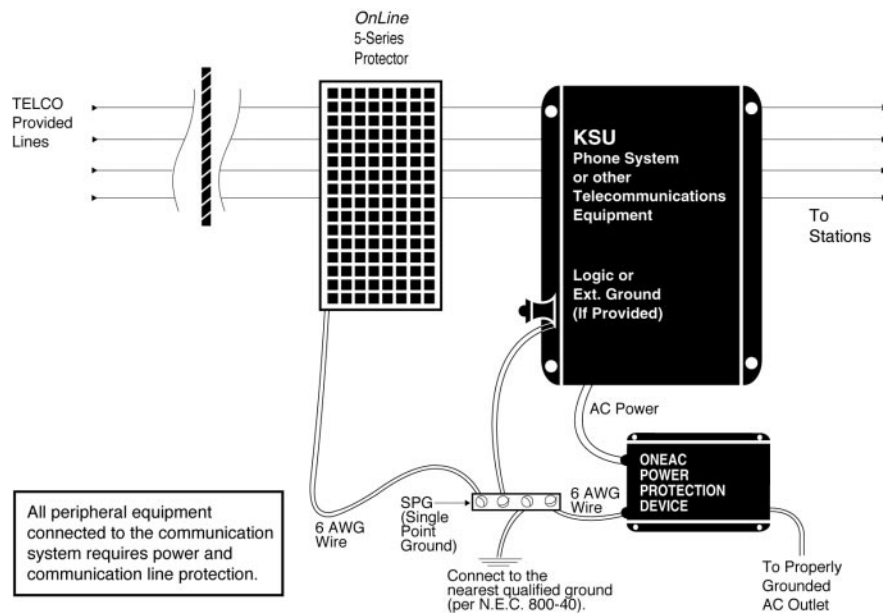

Fig 6 OnLine 5S-Series Circuit Drawing

**4.** When wiring, take the shortest and most direct path to ground. Avoid sharp turns and kinks in ground wires. With multiple installations, several ground bars can easily be daisy-chained together.

There are two options for grounding OnLine 5S-Series protector modules:

a) If your system is protected by an ONEAC Power Protection Device: Run a 6 AWG ground wire from the ground of the 5-Pin Base to the Single Point Ground. Next, run a 6 AWG ground wire from the Environmental Reference Ground screw on the ONEAC Power Protection Device to the Single Point Ground. Then, complete the installation by running a 6 AWG ground wire from the Single Point Ground to the nearest qualified ground.

— OR —

b) If your system is not protected by an ONEAC Power Protection Device: Run a 6 AWG ground wire from the ground of the 5-Pin Base to the nearest qualified ground.

**5.** Check phone line operation. If any test fails, recheck to ensure the OnLine protector modules are properly seated in the block.

**TIP AND RING TESTING:** The OnLine 5S-Series enables Tip and Ring testing without removing the modules from the 5-Pin Base. ONEAC's design provides easy access to the input side and enables technicians to probe their Telco Test Sets directly to OnLine 5S-Series protector modules. Therefore, there is no need to interrupt phone service while performing Tip and Ring tests.

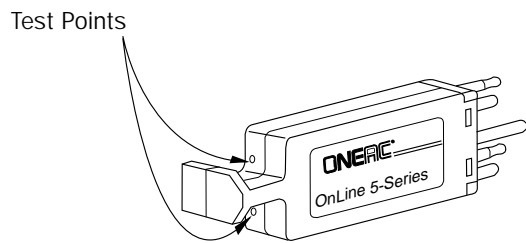

## OnLine 1-Series

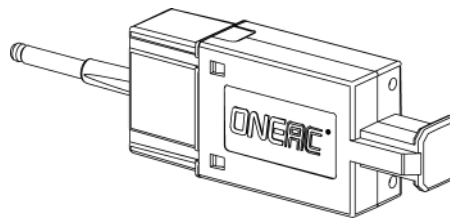

### Product Description

The ONEAC protector module incorporates an innovative, balanced Fail-Safe Design to ensure that both tip and ring will simultaneously fail to ground when either side is exposed to a fail-safe condition. Other protectors may have only one side fail-safe, while the other side retains continuity, placing the equipment behind it at risk.

The OnLine 1-Series protectors use patented "switched filter technology" that provides transient let-through voltages below the DC breakdown voltage of the protector, in combination with low loss and fast reaction time.

## General Requirements

The OnLine 1-Series protector modules provide primary protection for 1 pin protector bases. No installation is safe from phone line transient damage, unless OnLine 1-Series protector modules are installed on all phone lines.

- One OnLine 1-Series module is required for each line (twisted pair).
- Avoid bundling CO or OPX cable with inside wiring and ground conductors.
- All protector modules must be properly grounded for effective operation. In order to achieve Total Protection, ONEAC Power Protection Devices are recommended for protecting the phone system's AC power input, therefore providing the best grounding.
- Installation and grounding of primary protector modules must be in accordance with Local Codes and Article 800 of the National Electrical Code, ANSI/NFPA 70.
- Intended for indoor use only.
- Never install telephone wiring during a lightning storm.
- The 1-Series protector module meets UL 497 and CAN/CSA C22-2-92 when installed in a UL Listed 1 Pin Protector Base employing 30Ga. or smaller fusing wire.

**CAUTION:** *The OnLine 1-Series protector modules may contain resettable over-current (sneak current) protection. As soon as the failure clears, the protector modules will return to their normal state.*

## Tools and Materials for Installation

PORTA Type Base

### Installation

**1.** Install OnLine 1-Series protectors in the 1 pin protector base. The modules are keyed so the units can only be installed one way. When the module is fully inserted, subscriber or CO equipment is connected to the outside plant cable pair.

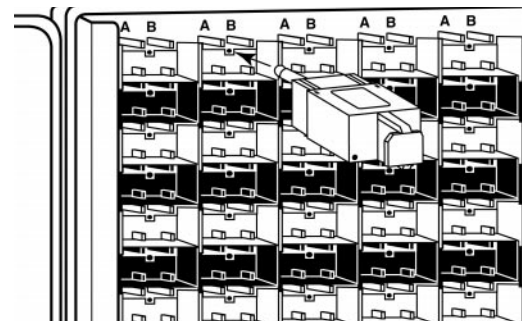

**2.** To disconnect the subscriber or CO equipment from the outside plant cable pair, pull out the OnLine 1-Series protector module slightly to obtain detent position.

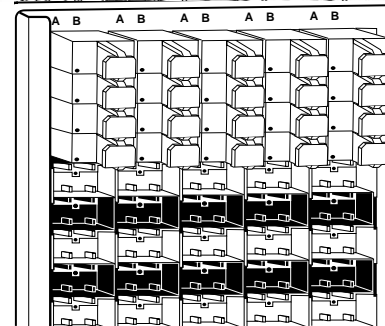

**NOTE:** *Note: The ground pin of the OnLine 1-Series protector module provides continuity to the 1 pin protector base ground terminal. The 1 pin protector base must be grounded to a locally approved grounding field for the OnLine 1-Series protector module to function properly.*

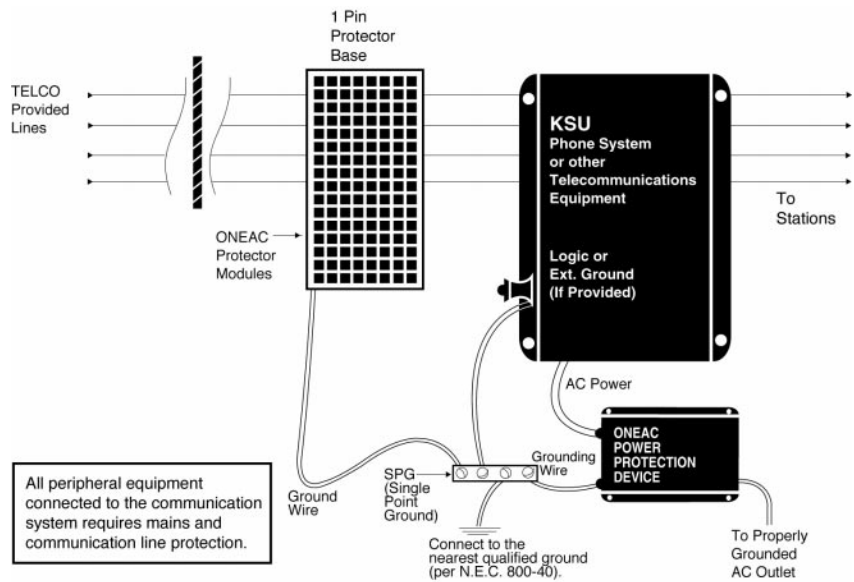

Fig 7 OnLine 1-Series Circuit Drawing

**3.** When wiring, take the shortest and most direct path to ground. Avoid sharp turns and kinks in ground wires. With multiple installations, several ground bars can easily be daisy-chained together.

There are two options for grounding OnLine 1-Series protector modules:

a) If your system is protected by an ONEAC Power Protection Device: Run a 6 AWG ground wire from the ground of the 1 pin protector Base to the Single Point Ground. Next, run a 6 AWG ground wire from the Environmental Reference Ground screw on the ONEAC Power Protection Device to the Single Point Ground. Then, complete the installation by running a 6 AWG ground wire from the Single Point Ground to the nearest qualified ground.

— OR —

b) If your system is not protected by an ONEAC Power Protection Device: Run a 6 AWG ground wire from the ground of the 1 pin protector base to the nearest qualified ground.

**4.** Check phone line operation. If any test fails, recheck to ensure the OnLine 1-Series protector modules are fully inserted in the 1 pin protector base.

## OnLine RJ-Series

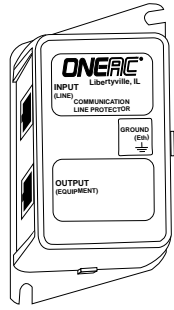

### Product Description

The OnLine RJ-Series module is a UL listed primary and secondary protector designed to work with RJ type wiring connectors that can be installed in accordance with Article 800 of the National Electrical Code, ANSI/NFPA 70. OnLine RJ-Series modules provide a high level of transient voltage protection for a wide variety of communications services.

The OnLine RJ-Series protectors use patented “switched filter technology” that provides transient let-through voltages below the DC breakdown voltage of the protector, in combination with low loss and fast reaction time.

### Product Specifications

The input and output RJ (jacks) have straight-through connections.

*Table 1. RJ Protected Pairs*

RJ	Input	Output
AP or DP11	3,4	3,4
AP or DP14	3,4 2,5	3,4 2,5
AP or DP45	1,8 2,7 3,6 4,5	1,8 2,7 3,6 4,5

### General Requirements

- The Online RJ-Series protector modules provide primary and secondary protection. No installation is safe from phone or data line transient damage, unless Online RJ-Series protector modules are installed on all phone or data lines.
- When employed for primary protection, the Online RJ-Series protector modules must be used with fusing conductors no larger than 24 AWG wire.
- Prior to installing protector modules, disconnect the phone or data line(s) at the network interface.
- Avoid bundling phone or data line cables with inside wiring and ground conductors.
- The ground wire must not be any smaller than 12 AWG for RJ11 and RJ14 models.
- The ground wire must not be any smaller than 10 AWG for RJ45 models.
- All protector modules must be properly grounded for effective operation. In order to achieve Total Protection, ONEAC Power Protection Devices are recommended for protecting the phone system’s AC power input and provide the best grounding.
- Installation and grounding of primary/secondary protector modules must be in accordance with Local Codes and Article 800 of the National Electrical Code, ANSI/NFPA 70.
- Intended for indoor use only.
- Never install protectors or wiring during a lightning storm.

**CAUTION:** Certain models of the Online RJ-Series protector modules contain resettable over-current protection (sneak current). As soon as the fault has cleared, the protector modules will return to their normal state.

### Tools and Materials for Installation

- Phillips Screwdriver
- Two #8 Screws
- Grounding Conductor
- Template for Wall Mounting
- Double-Faced Tape
- Telephone or Data Line Cord, 26 AWG

### Installation

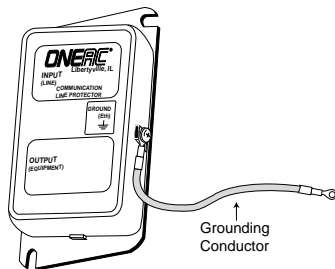

**1.** Grounding of Module: Make sure the grounding conductor is securely fastened to the RJ-Series protector module.

**2.** Wall Mounting: Mount the RJ protector module securely with the #8 screws, where applicable. (Use the template provided.)

**NOTE:** The double-faced tape can be used for temporary mounting on suitable surfaces.

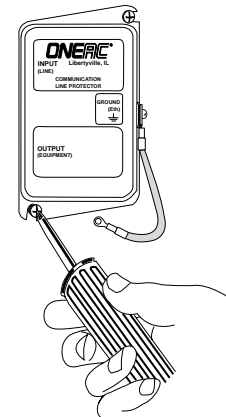



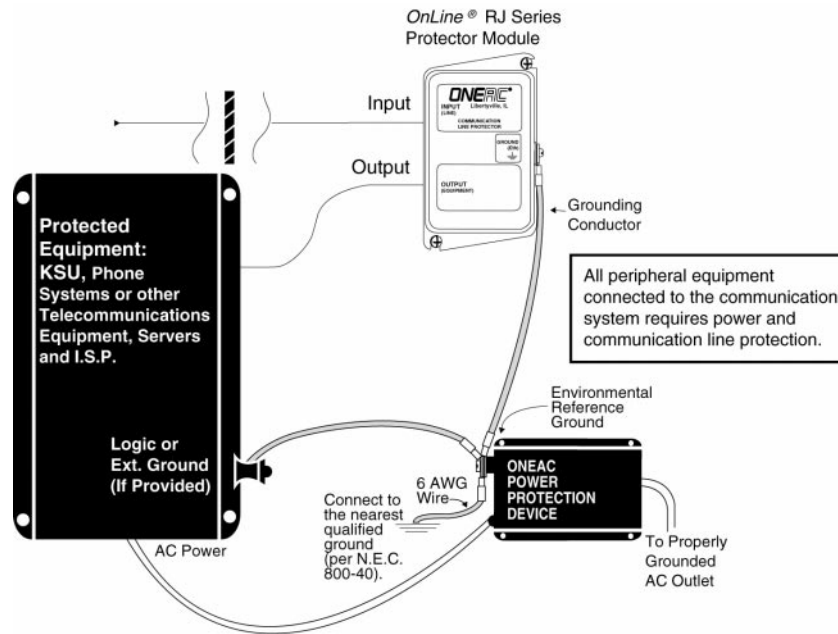

Fig 8 OnLine RJ -Series Circuit Diagram

**3.** Connecting Grounding Conductor to the Grounding Electrode: When wiring, take the shortest and most direct path to ground. Avoid sharp turns and kinks in ground wires.

- a) If your system is protected by an ONEAC Power Protection Device (PPD), connect the grounding conductor of the RJ protector module to the Environmental Reference Ground screw of the ONEAC PPD and continue with a 6 AWG ground wire from the Environmental Reference Ground screw to the nearest qualified ground.
- b) If your system is not protected by an ONEAC PPD, connect the grounding conductor to the nearest qualified ground.

**4.** Input/Output Connections: Make the appropriate connections to the “input/output” jacks. Use the telephone or data line cord to connect the telephone or data line to the input jack, and make sure the equipment to be protected is connected into the output jack.

**5.** Final Installation Check:

- Verify the input and output plugs are fully inserted.
- Check that all telephone/data communication equipment is operational.

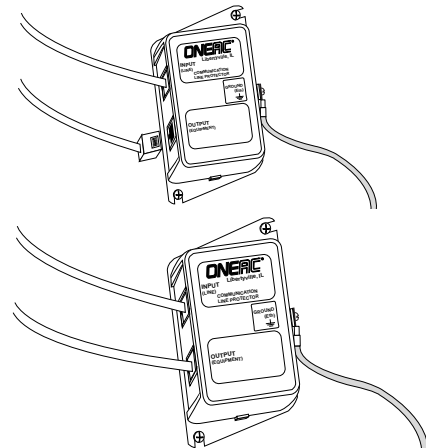

## Convergent Series™

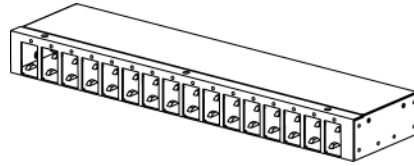

### Product Description

The Convergent Series protector module is a UL listed primary and secondary protector designed to work with RJ type wiring connectors that can be installed in accordance with Article 800 of the National Electrical Code, ANSI/NFPA 70.

The 16-port rackmount base unit can be attached directly to a flat surface or mounted in a standard 19" relay rack. The 5-port and 10-port units are surface mount only.

The Convergent Series protectors use patented “switched filter technology” that provides transient let-through voltages below the DC breakdown voltage of the protector, in combination with low loss and fast reaction time.

Together, the protector modules and base units provide a high level of transient voltage protection for a wide variety of communications services.

### General Requirements

- The Convergent Series protector modules provide primary, secondary or data line protection. No installation is safe from communication line transient damage unless Convergent Series protector modules are installed on all communication lines.
- When employed for primary protection, the Convergent Series protector modules must be used with 26 AWG or physically larger hook up wire.
- Prior to installing protector modules, disconnect the phone or data line(s) at the network interface.
- Avoid bundling phone or data line cables with inside wiring, power and ground conductors.
- The ground wire must not be any smaller than 6 AWG.
- All protector modules must be properly grounded for effective operation. In order to achieve Total Protection, ONEAC Power Protection Devices are recommended for protecting the communication system's AC power input and provide the best grounding.
- Installation and grounding of primary/secondary protector modules must be in accordance with Local Codes and Article 800 of the National Electrical Code, ANSI/NFPA 70.
- Intended for indoor use only.
- Never install protectors or wiring during a lightning storm.

### Tools and Materials for Installation

1/8" Blade Screwdriver

### Installation

**I.** Mounting of Module: Insert the Convergent Series protector module into an empty location in the rackmount base unit (see diagram). Fasten it in place with the screw provided. Tighten the screw in order to ensure proper grounding of the module to the rack mount base unit.

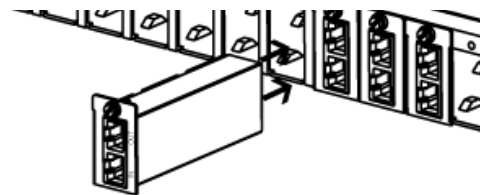

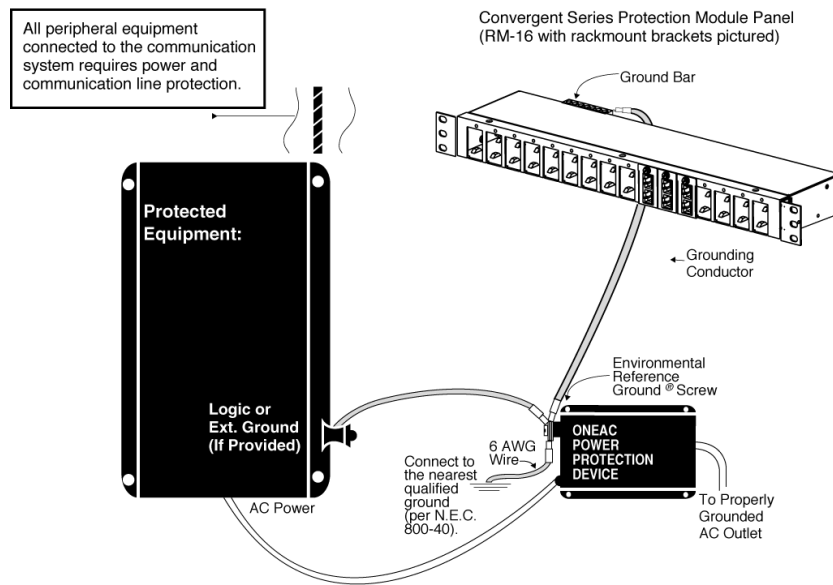
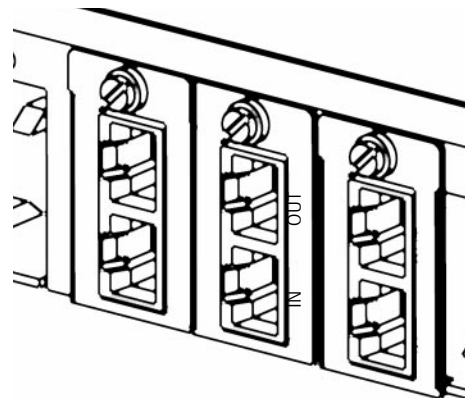

Fig 9 Convergent Series Circuit Diagram

2. **Connecting Grounding Conductor of the Rack Base Unit to the Grounding Electrode:** When wiring, take the shortest and most direct path to ground. Avoid sharp turns and kinks in ground wires.
  - a) If your system is protected by an ONEAC Power Protection Device (PPD), connect the grounding conductor of the Convergent Series Rack Base Unit to the Environmental Reference Ground screw of the ONEAC PPD and continue with a 6 AWG ground wire from the Environmental Reference Ground screw to the nearest qualified ground.
  - b) If your system is not protected by an ONEAC PPD, connect the grounding conductor to the nearest qualified ground.

3. **Input/Output Connections:** Make the appropriate connections to the input/output jacks. Connect the data line to the input jack, and make sure the equipment to be protected is connected to the output jack.

4. **Final Installation Check:**
  - Verify the input and output plugs are fully inserted.
  - Verify that each mounting screw is tight.
  - Check that all data communication equipment is operational.



## Single Point Ground Adapter Kit for ONEAC Power Protection Devices

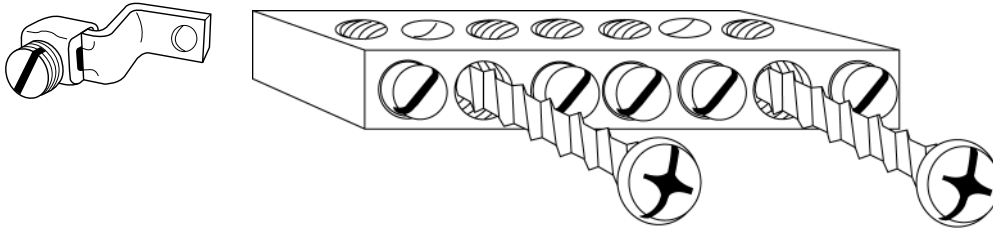

### Product Description

ONEAC's Single Point Ground Adapter Kit (350-055) enhances the usefulness of the Environmental Reference Ground (ERG) on the back panel of the ONEAC Power Protection Device (PPD). The kit contains a Single Point Ground Screw (SPG Screw) and a Single Point Ground Bar (SPG Bar) with mounting screws. The SPG Screw attaches to the ERG stud. The adapter kit makes it simple to connect the ERG to the Single Point Ground Bar with a 6 AWG wire.

### Tools and Materials for Installation

- Straight Blade Screwdriver
- Phillips Screwdriver
- 6 AWG Wire
- Nutdriver

**CAUTION:** Before installing the Single Point Ground Adapter Kit, be sure that the ONEAC PPD is not connected to the power source.

### Installation

- 1.** For ONEAC Power Protection Device (PPD) Installations: Place the PPD near the equipment that will be protected. Allow about six inches of clearance around the PPD for access to the ERG stud or screw.
- 2.** Remove the nut or screw on the PPD's Environmental Reference Ground (ERG). See A or B for your PPD ERG type.

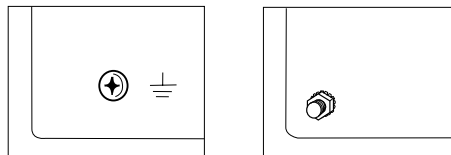

- 3.** Install the SPG Screw Be sure to securely tighten the nut or screw.

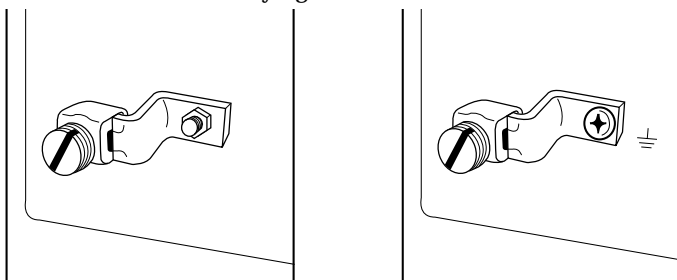

*Installing ONEAC Total Protection Solutions Sections 1 - 4*

**4.** Mount the SPG Bar on the wall or back-board at the most desirable location with the two screws provided.

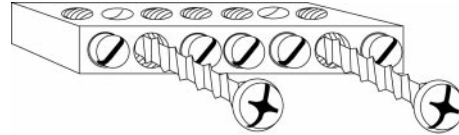

**5.** Run 6 AWG wire from the ONEAC PPD to the SPG Bar. Take the shortest and most direct path to the ground. Avoid sharp turns.

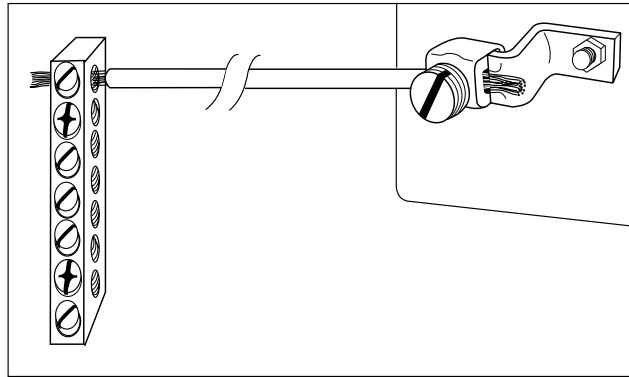

**6.** Check that all set screws are tightened securely.

**7.** Connect the PPD to its power source. Turn on the PPD and the equipment being protected.

**8.** This completes the installation of the Single Point Ground Adapter Kit.

## Section 3: Total Protection Solution Installed

PBX Applications: Fig 10 represents the optimum power and grounding arrangement. If, however, this installation diagram conflicts with the manufacturer's recommended procedures, the installing technician should follow the manufacturer's practice as follows:

- ALL power and communications lines must be protected by ONEAC Total Protection Solution Devices.
- The ONEAC Single Point Ground (SPG) must be utilized.

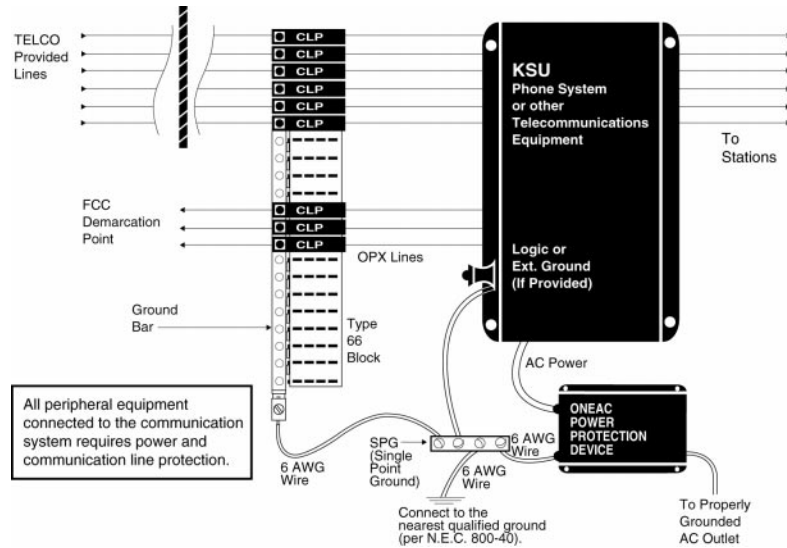

Fig 10 Optimal Power and Grounding Arrangement

## Section 4: OPX Cable Application

**NOTE:** The installation or acceptance of cable that is either unshielded or is without cable-shield continuity is not recommended. All OPX cable must be installed and maintained in accordance with the National Electrical Code (N.E.C) requirements.

Refer to the N.E.C reference section of this handbook. ONEAC will not support applications where OPX cable does not meet the N.E.C. Installation Instructions

1. Use only shielded cable for OPX applications.
2. Cable shields should be inspected for cable sheath continuity and bonding/grounding per N.E.C. requirements.
3. Use only approved bonding clamps/harnesses specifically designed for cable use.
4. Tighten all cable bonds and grounds to insure their integrity.
5. Do not ground unused spare pairs.
6. Install ONEAC Communications Line Protection Devices (CLPDs) on ALL lines and ground them per the installation instructions.



## **Part 6: National Electrical Code Section**

Related Code Articles:

Article 210 Branch Circuits

Article 250 Grounding

Article 300 Wiring Methods

Article 800 Communications Circuits





A CHLORIDE POWER PROTECTION COMPANY

ONEAC Corporation, a wholly owned subsidiary of Chloride Group, PLC was founded in 1979. ONEAC designs and manufactures products that provide the highest level of protection against power and data line disturbances, regardless of conditions. ONEAC's comprehensive product lines include power conditioners, uninterruptible power supplies, DC power solutions and voice & data line protection devices. With ISO9001 certified manufacturing plants in the U.S. and U.K., ONEAC is dedicated to demand-flow manufacturing and the highest quality standards.

Organizations whose productivity goals allow no possibility for system downtime use ONEAC. They include many of the world's leading companies, in a wide range of applications including telecommunication systems, information technology, retail information systems, computer-integrated manufacturing systems, semiconductor test equipment and biomedical instrumentation and information systems. Information on ONEAC products and services is available on the Internet at [www.oneac.com](http://www.oneac.com).

**ONEAC USA**

27944 North Bradley Road  
Libertyville, IL 60048-9700  
United States  
Toll Free: (800) 327-8801  
Tel: (847) 816-6000  
Fax: (847) 680-5124

Visit our website: [www.oneac.com](http://www.oneac.com)

**ONEAC EUROPE**

George Curl Way  
Southampton, Hampshire SO18 2RY  
United Kingdom  
Tel: +44-(0)-2380 610311  
Fax: +44-(0)-2380 612039

ONEAC, OnLine and Environmental Reference Ground are registered trademarks and Convergent Series is a trademark of ONEAC Corporation. All other trademarks are the property of their respective companies.

Entire contents ©2002 ONEAC Corporation. All rights reserved. Reproduction in whole or in part without permission is prohibited. All information subject to change without notice.

Printed in the U.S.A.

Form No. 913-323 Rev. B